

- DESIGN CRITERIA:
- SEISMIC CATEGORY C
 - WIND LOAD - 110 MPH
 - FLOOR LIVE LOAD - 250 PSF
 - CONCRETE 5000 PSI
 - REBAR ASTM A615 GRADE 60

- DOOR OPTIONS:
- 3'-0" x 6'-8" SINGLE EXTERIOR DOOR
 - 6'-0" x 6'-8" DOUBLE EXTERIOR DOOR
 - 6'-0" x 7'-0" STEEL ROLLUP DOOR
 - CUSTOM DOOR SIZES AVAILABLE

EXTERIOR FINISH: PER CUSTOMER SPECIFICATION

EXTERIOR COLOR: PER CUSTOMER SPECIFICATION

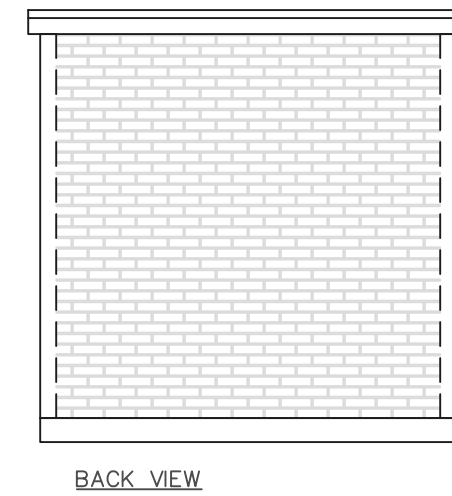
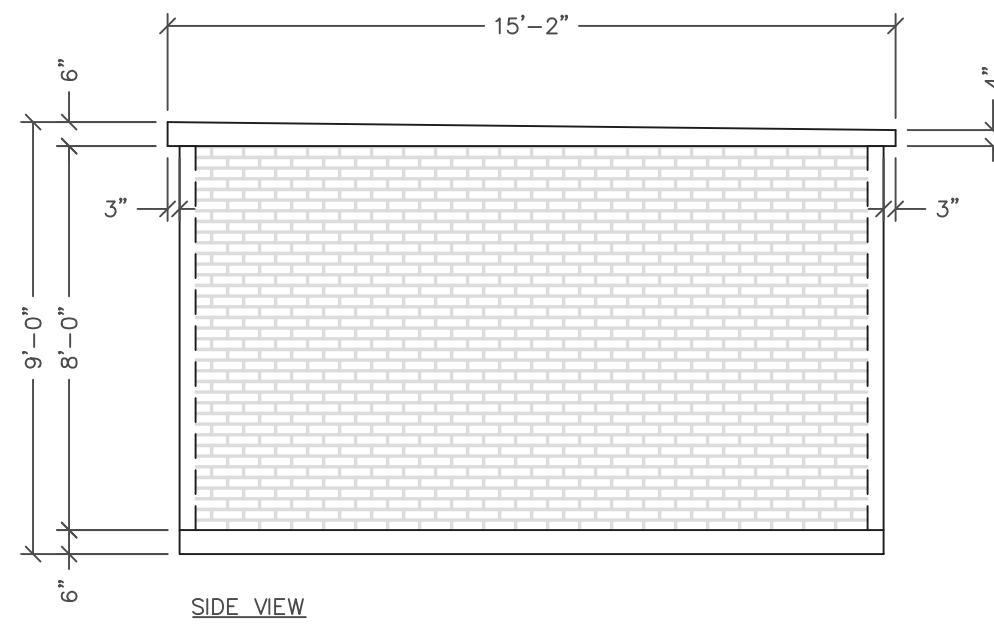
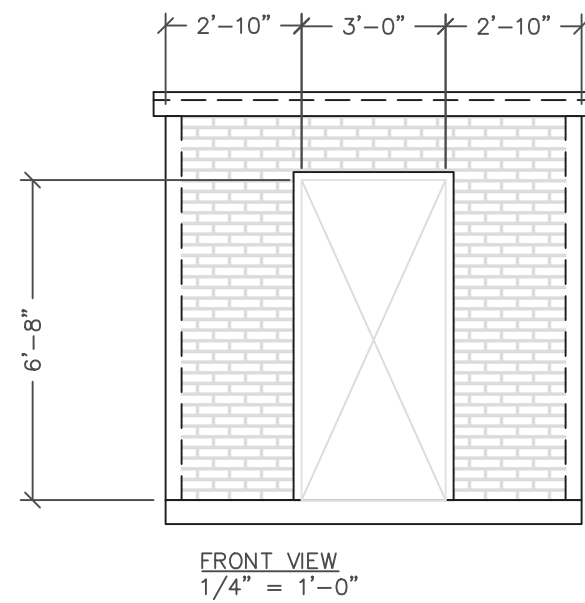

www.trucast.com

ZEELAND, MI

8' x 14'
UTILITY/STORAGE
BUILDING